

Oregon Process Innovation Center (OPIC) for Sustainable Solar Cell Manufacturing

Chih-hung (Alex) Chang

*School of Chemical, Biological, and Environmental Engineering
Micro-product Breakthrough Institute
Oregon State University
(541)7378548
changch@che.orst.edu*

Oregon **BEST FEST '09**
September 14 | Portland, Oregon



Opportunity

The key enabler for creating a sustainable PV industry is to develop more energy efficient, more material efficient, greener, low-cost manufacturing processes for both existing and future versions of high efficiency solar cells.

Mission

Oregon Process Innovation Center for Sustainable Solar Cell Manufacturing is to serve Oregon as:

- *A collaborative center for PV industry and academic researchers to develop innovative processes for sustainable manufacturing.*
- *A resource (facility, person power and expertise) for solving PV industry manufacturing problems.*
- *A resource for developing next generation solar cell manufacturing processes.*
- *A training ground for PV industry future workforce.*

Nano/Micro Fabrication Facility

within the Microproducts Breakthrough Institute



NMF Equipment

- Microfluidic Design Studio
- Microlamination
 - Patterning
 - Bonding
- Surface Deposition
- Characterization



NMF Capabilities

- Design Studio

- Fab

 - Shells

 - Surfaces

- Characterization

- Machine Shop

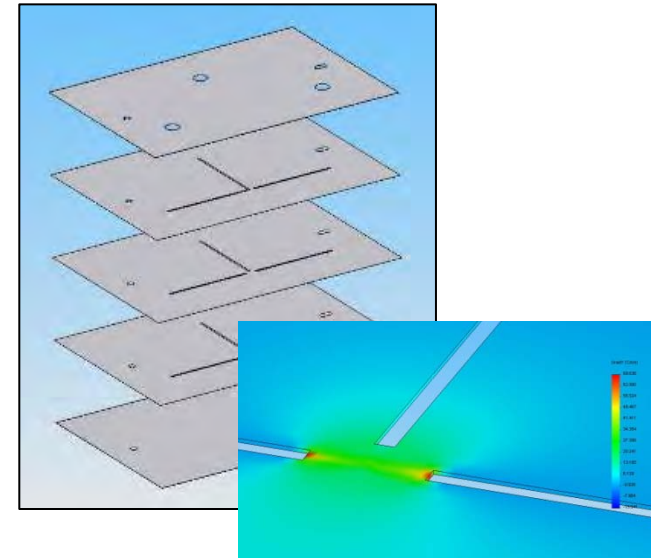

- Solidworks
- COMSOL
 - Device analysis
- COSMOS
 - Manufacturability analysis
 - Thermal and stress analysis
- CFDRC
 - CFD and thermal analysis

NMF Capabilities

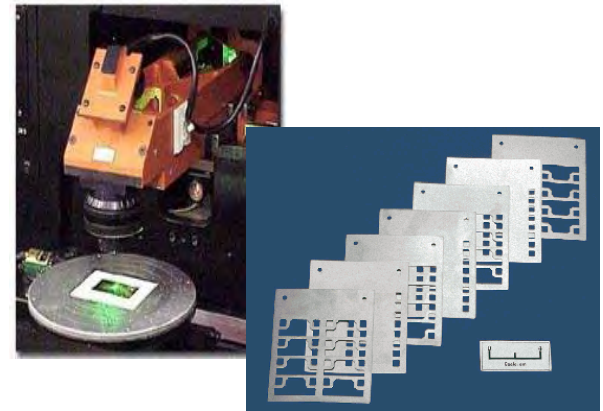

Courtesy of DOE ARC

- Design Studio
- **Fab**
 - Shells
 - Surfaces
- Characterization
- Machine Shop
- Laser micromachining
 - Deep UV (266 nm)
 - UV (355 nm)
 - Green (532 nm)
- (Isotropic etching)
- microEDM
- Electrochemical etching
- Electroforming
- Microembossing
- Nanoimprinting
- Injection molding
- CNC micromilling
- Ultrasonic machining

NMF Capabilities

- Design Studio
- **Fab**
 - Shells
 - Surfaces
- Characterization
- Machine Shop

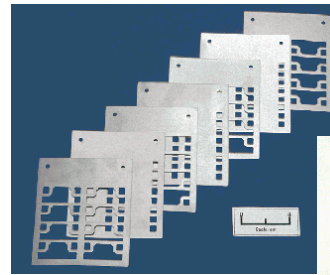

Courtesy of DOE ARC

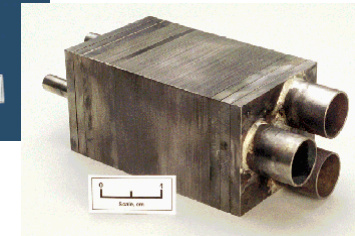

- Diffusion bonding
- Diffusion brazing
- Diffusion soldering
- Solder paste bonding
- Laser transmission welding
- Thermal adhesive
- UV adhesive
- Pressure-sensitive adhesive
- Solvent welding
- Ultrasonic welding

NMF Capabilities

- Design Studio
- **Fab**
 - Shells
 - **Surfaces**
- Characterization
- Machine Shop

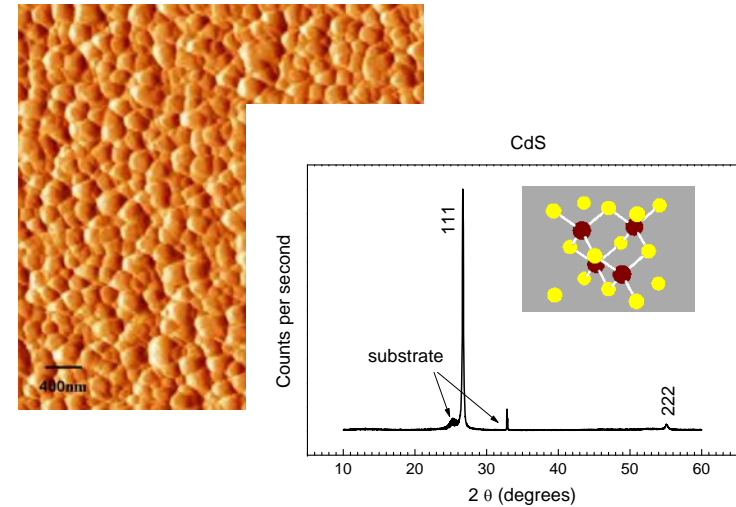

- Plasma Cleaning/Prep
- Sputtering
- Atomic Layer Deposition
- Microreactor-assisted Nanoparticle Deposition
- Microreactor-assisted Solution Deposition
- (Molecular Beam Epitaxy)

NMF Capabilities

- Design Studio
- Fab
 - Shells
 - Surfaces
- **Characterization**
- Machine Shop

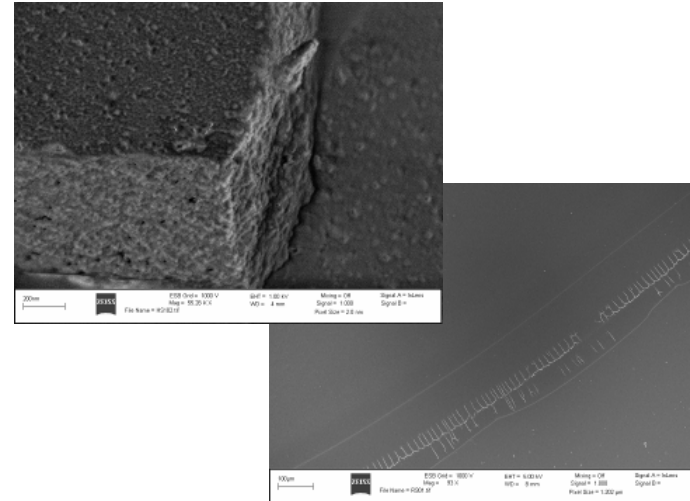

- Laser scanning microscope
- Contact profiler
- Optical microscopes at all mags with video/image capture
- Gas chromatography
- Liquid chromatography
- Scanning electron microscope

Oregon Process Innovation Center within the Microproducts Breakthrough Institute

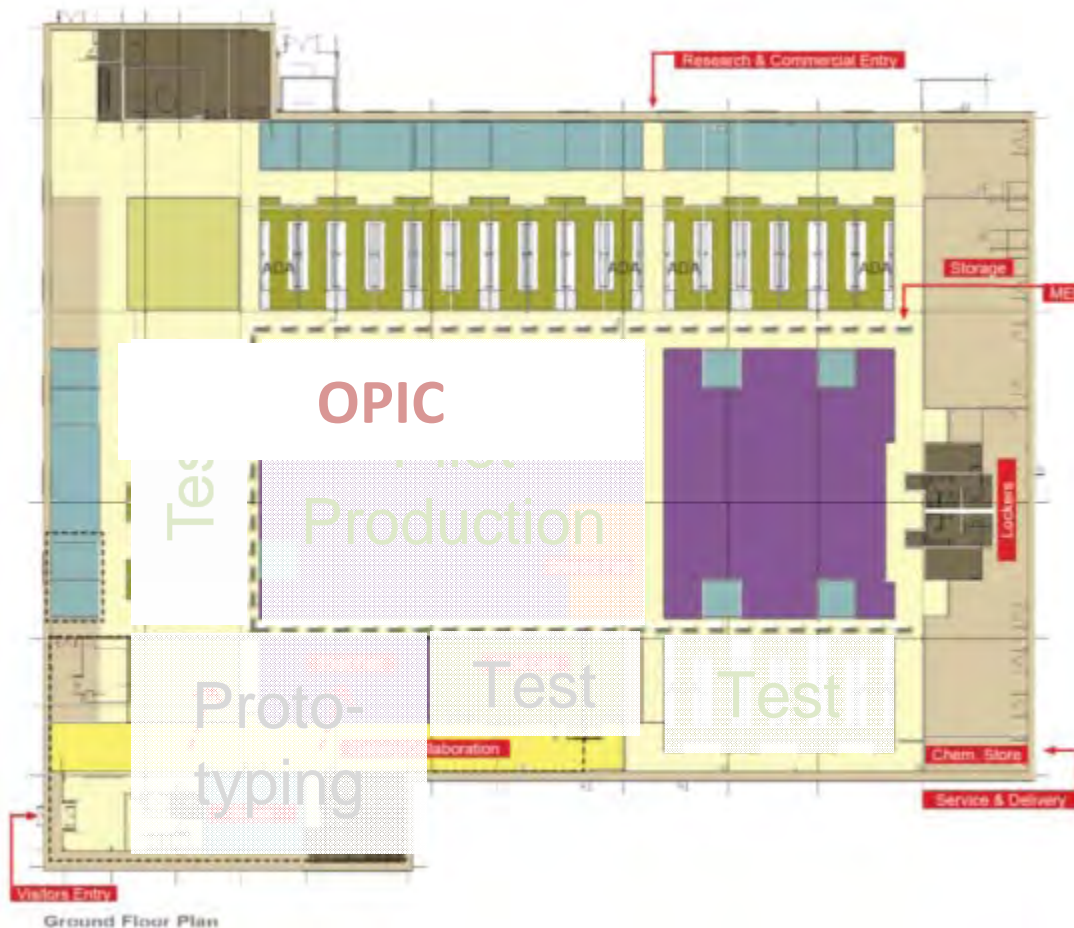

OPIC Equipment

- Novel Process Equip
 - Roll-to-roll printers
- Process Diagnostics
 - In-situ Mass Spec
 - In-situ FTIR Spec
 - Atomic Force Microscope
 - Nanolithography



In-situ Process Diagnostic Tools

Bruker FTIR Reaction Monitoring System

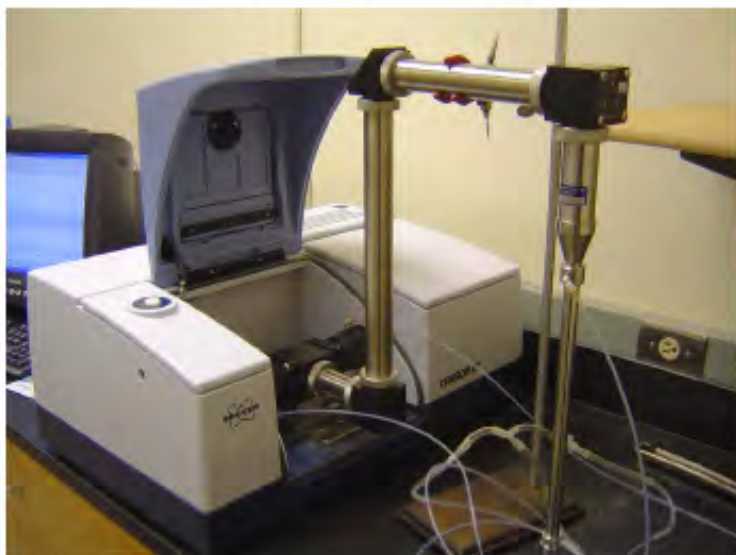

High performance ATR probe for in-situ FTIR reaction, including a high Pressure ATR Immersion Probe Sensing Head.



HPR-20 QIC

Advanced real-time gas analysers for continuous sampling of processes and atmospheres near ambient pressure.

Innova SPM

- Contact Mode
- Tapping Mode™
- Conductive AFM
- Electric Field Microscopy
- Nanolithography

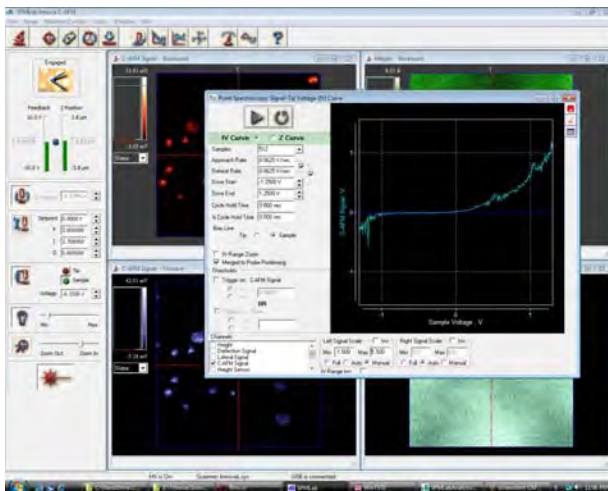
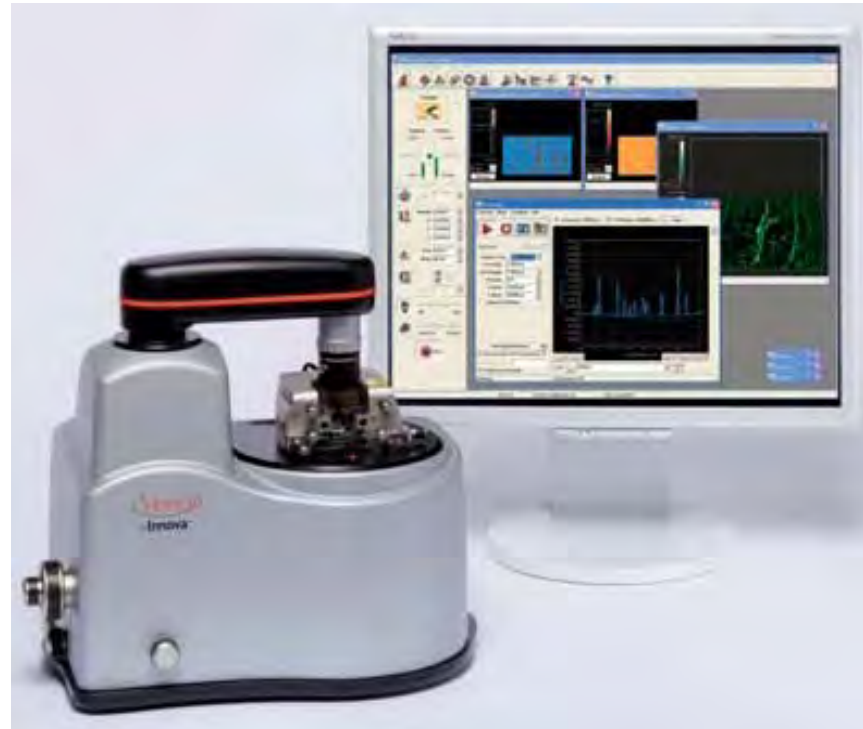

Shown here is the probe positioning tool, used in conjunction with IV spectroscopy to interrogate a dielectric breakdown spot.

Roll-to-Roll Coater

Proposal submitted seeking additional funding for larger coater



Tabletop Test Coater “Micro Gravure™” –

Direct/Reverse/Kiss/Gravure method with trailing doctor blade.

YASUI SEIKI
Micro Coater™

- 1 Compact!**
Dryer Unit and Unwinder & Rewinder units included!
Optional UV-curing system
- 2 Test Coating is Easy!**
- 3 Utilizes patented-Micro Gravure® Technique!**
Coating is possible through a wide range of coating thicknesses from only 1 μm wet to up to 40+ μm wet coatings.
Exchanging coating rolls is easy.
The rolls are so slender they won't take up-storage space.
- 4 Maximum coating width is 300mm!**

Electronic Components / Secondary Battery Applications	Optical Applications	Others
Photoresist (Photoresist)	Reflective Ad Film	When you demand Thin Film
Sliver Release	LED package film	Less Expensive than Sputter coating
Touchscreen underlayer coating		
Lithium Secondary cell		
Battery separator		
Solar Battery related		

Oregon **BEST FEST '09**
September 14 | Portland, Oregon



OPIC

Oregon Process Innovation Center (OPIC) for Sustainable Solar Cell Manufacturing will provide:

- Shared equipment for research, development and problem solving;
- Lab space for performing projects;
- Office space for participating researchers;
- Mechanisms and opportunities to form innovative research teams.



OPIC Operating Strategy : Example



3.0 FTE MBI staff currently exists



Project Example: Photovoltaic Films

Microreactor-Assisted Nanomaterial Deposition™ [Chang/Paul 2007]

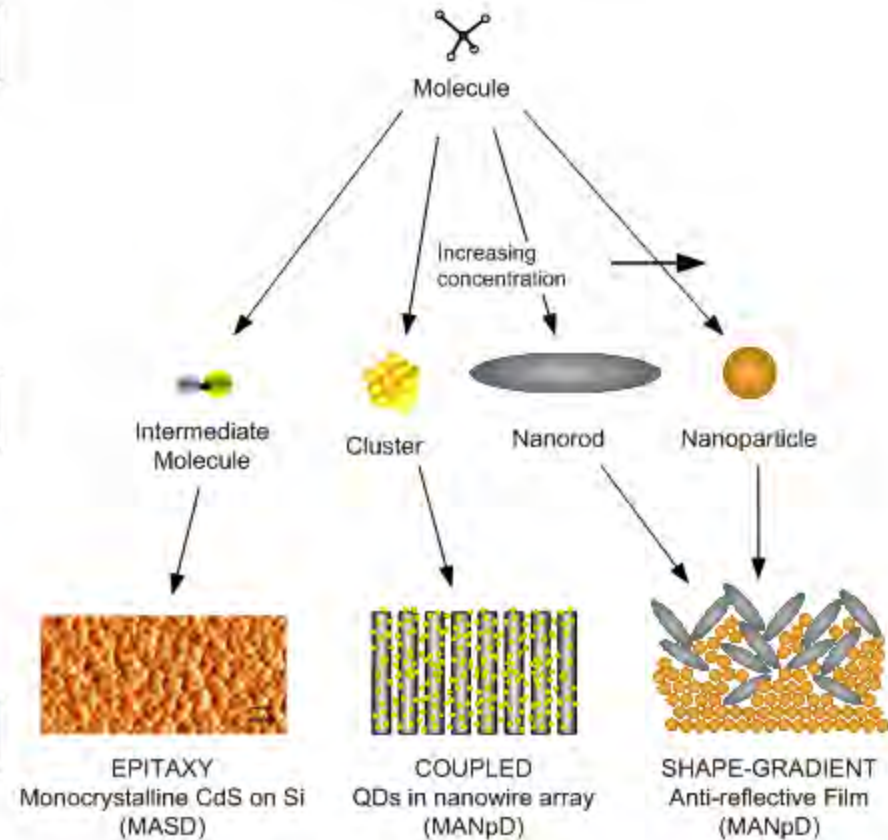
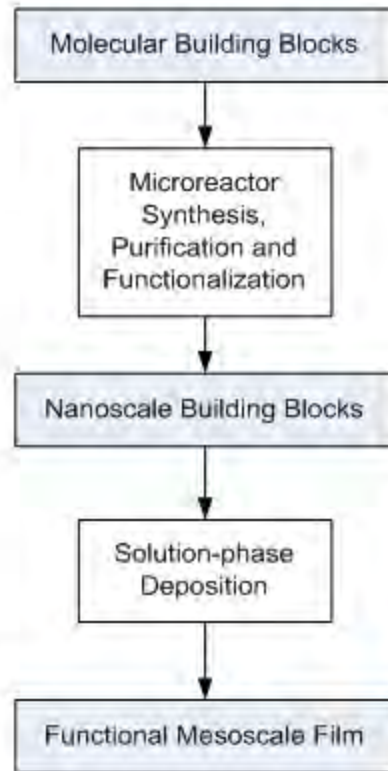
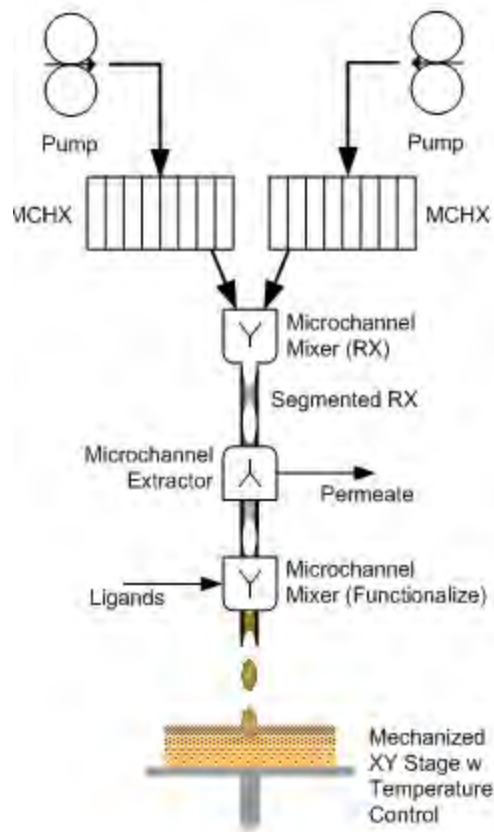

Microreactor-Assisted Nanomaterial Deposition™ Technology for Photovoltaic Material Production

U.S. DOE, Office of EERE ITP program

*PIs: Dan Palo, Chih-hung Chang, Brian K. Paul, Vincent T. Remcho
Shane Addleman, Michael O'Hallaron, Dave Schut*

- Transformational Elements
 - Just-in-time nanomanufacturing – avert agglomeration
 - Coupled production, purification, and large-format deposition technologies
- Industrial Applications and Market Potential
 - Technology insertion for existing and upcoming PV production lines
 - Lower processing temperatures and solvent usage
 - Enable greener nanomaterials production and deposition for high-efficiency PV
- Project Team

